



# PIPE BENDING MACHINE

## SUPER 6" - 20"

### Design Features

- T1 Steel body construction for long life and extra strength
- Calibrated Indicator Rod for precise repeatable pipe bends
- Single operator control station for all functions
- PTFE sealing system in all cylinders
- Designed to bend all grades of API-5L pipe within its range
- Hydraulic Mandrel connection with 3/8" quick disconnect couplings
- Easily towed on the right of way by a suitable tractor
- Towing eye can be raised and lowered by actuating the Stiffback controls



### HYDRAULICS

	BORE (IN)	STROKE (IN)	ROD (IN)
InBoard Cylinder	8	6	2.25
OutBoard Cylinder	8	14	6
Pin Up Cylinder	5	23	2.25
Clamp Cylinder			
Pump Type	Vane, Fix Volume		
Pump Flow	46 gpm		
Valve Type	Manual, 3 or 5 Section		
Filtration	3 Micron, Pressure Line		
Hydraulic System Max Operating Pressure	3000 psig		
Hydraulic Reservoir	50 gal	187.5 L	

#### Disclaimer:

Technical information provided for this equipment regarding performance, specifications, dimension and weights can vary depending on final configuration of the equipment. Please contact DMI International for actual specifications at time of shipment.

DMI International does not accept responsibility for errors regarding the technical information, nor the consequences of any errors, nor the consequences to changes in the specifications contained herein. DMI International reserves the right to modify the equipment performance and specifications without notice.

## PIPE BENDING CAPACITY

	Dia (in)
Minimum	6.625
Maximum	20

## SPECIFICATIONS

Length w/ Tires	19'-4"	5,588 mm
Width	7'-6"	2,286 mm
Height	7'-8"	2,337 mm
Weight with Tires (lbs/kg)	14,160 lbs	6,436 kg
Pneumatic Tire Size	11.0 x 16	
Weight with Tracks (lbs/kg)	16,400 lbs	7,439 kg
Track Size	10 Ton	

## ENGINES

Perkins Diesel	67	hp
Operating Speed	2200	rpm
Fuel Tank	15	gal

## COMPRESSOR

Manufacturer	Quincy QR-325
Drive Type	Hydraulic Motor
Pressure	210 psig
Flow	17.4 acfm @ 175 psig

## WINCH

Manufacturer	Ramsey
Drive Type	Hydraulic Motor
Pulling Force	10,000 lbf
Cable Diameter	.4375"
Free Wheeling Drum	

## OPTIONS AVAILABLE

- Caterpillar C4.4 Tier 3 Diesel Engine (Export Only)
- Hydraulic-driven air compressors
- Two or Three Stage Pump
- Tires or Tracks
- Cold weather operating kit (-40°) available

NOMINAL PIPE O.D.	MAXIMUM WALL THICKNESS BY GRADE						RECOMMENDED BEND		
	IN/MM	X52	X60	X65	X70	X80	X100	DEGREE PER ARC FOOT	RADIUS FEET
20/508	1.454	1.257	1.158	1.074	0.938	0.748	2.72	69	24.35
18/457	1.930	1.648	1.511	1.395	1.209	0.955	3.61	52	32.32
16/406	-	-	-	1.956	1.667	1.288	4.95	38	44.31
14/356	-	-	-	-	-	1.943	5.58	34	49.95
12.75/324	-	-	-	-	-	-	7.55	25	67.59
10.75/273	-	-	-	-	-	-	9.38	20	83.97
8.625/219	-	-	-	-	-	-	12.53	15	112.17
6.625/168	-	-	-	-	-	-	14.47	13	129.53

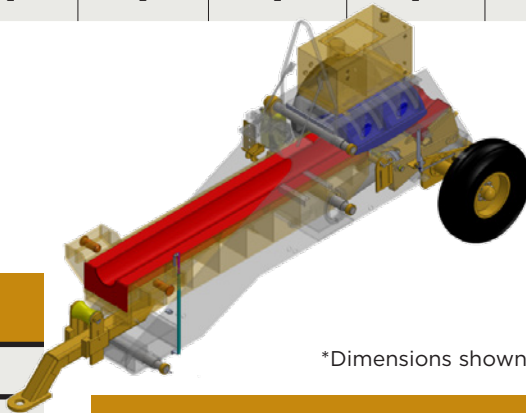

DMI bending sets and dies come bare or lined with urethane.

A bare bending set and die can be used to bend heavily coated pipe, ie: coal tar, asphalt and polyurethane coated pipe up to 5mm thick. Pipe exceeding 5mm or more in thickness will require a special bending set.

Urethane lined bending sets are used for regular epoxy coated pipe.

\*Dimensions shown for bending sets are shipping dimensions

## SUPER 6" - 20" LINED BENDING SETS

SIZE	WEIGHT	
	lb	kg
6"	1300	590
8"	1380	626
10"	1460	662
12"	1460	662
14"	1550	703
16"	1620	735
18"	1840	835
20"	1220	553

## SPECIFICATIONS FOR SUPER 6" - 20" LINED BENDING SETS

		LENGTH		WIDTH		HEIGHT	
		in	mm	in	mm	in	mm
<b>Super 6 - 20</b>	Stiffback	120.5	3061	21.25	540	10	254
	Pin Up	13.25	337	21.25	540	10	254
	Die	41	1041	24	610	16	406